

12MR1000 PRO

Professional Mid Range Driver



KEY FEATURES

- 3" Voice coil
- 1000 Watts continuous program power
- 99 dB Sensitivity
- 70 - 6,500 Hz



GENERAL SPECIFICATIONS

Nominal Diameter	12" (305 mm)
Nominal impedance	8 Ohm
Nominal Power Handling	500 Watts
Continuous Program Power (RMS)	1000 Watts
Max Peak Power	2000 Watts
Sensitivity 2.83V at 1m	99 dB
Recommended Hi Pass Crossover*	125 Hz*
<small>*For Full Power Handling</small>	<small>*12db Per Octave Crossover</small>
Frequency Response	70 - 6,500 Hz
Voice Coil Diameter	3" (75 mm)
Voice Coil Wire	CCAW
Voice Coil Winding Depth	11.0 mm
Former Material	Glass fiber
Magnetic Gap Depth	10 mm
Frame Material	Die cast Aluminum

THIELE-SMALL PARAMETERS

Equivalent Volume	Vas	92.3 l
Excursion (mathematical)***	Xmax	3.00 mm
Free Air Resonance	Fs	49.4 Hz
Mechanical Factor	Qms	12.05
Electrical Factor	Qes	0.40
Total Factor	Qts	0.39
Cone Area	Sd	577 cm ²
Mechanical Mass	Mms	52.31 g
Bl Factor	Bl	15.89 Tm
Dc Resistance	Re	6.2 Ohm
Inductance	Le	0.60 mH at 1 kHz
Mechanical Mass Without Air	Mmd	44.5 g
Mechanical Compliance	Cms	0.199 mm/N

EXTRA INFO

Overall Diameter	12.40" (315 mm)
Front Mount Baffle Cutout	11.16" (283.5 mm)
Mounting Depth	5.12" (130 mm)
Overall Depth	5.61" (142.5 mm)
Net Weight	16.30 Lbs (7.40 kg)
Shipping Weight	17.80 Lbs (8.06 kg)
Carton Dimensions W x L x H	13.38" x 13.38" x 7.09" (340 x 340 x 180 mm)

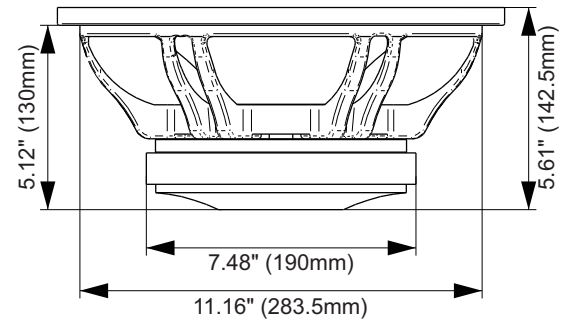
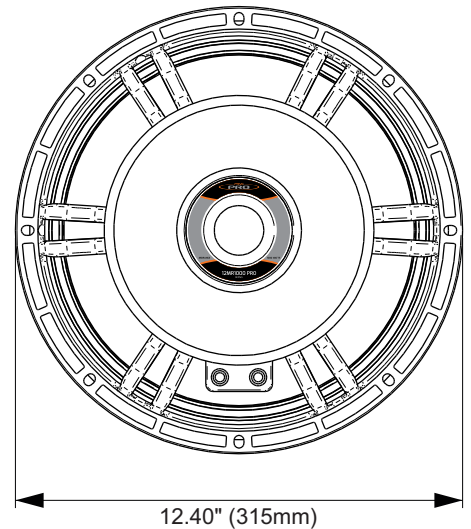

Impedance Curve - Free Air

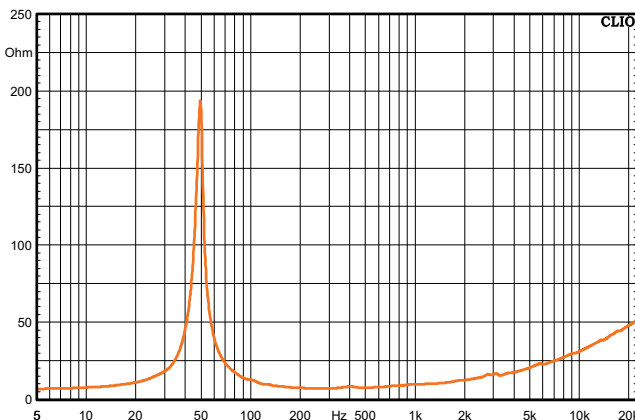

Frequency Response Measured at 2.83V/1m

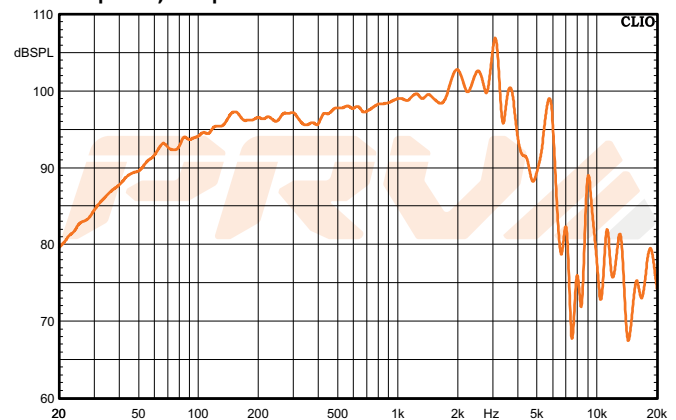

**Xmax=(Voice coil winding depth-Magnetic Gap depth)/2+ Magnetic Gap Depth/4
 *** T-S parameters measured after 2 hours at 1/2 Rated power, pink noise preconditioning test

PRV AUDIO USA (USA and Export)
 POMPANO BEACH, FL
 support@prvaudio.com
 www.prvaudio.com