

TW1000Ph

Professional Super Tweeter



KEY FEATURES

- 1.83" Voice coil
- 100 Watts continuous power handling
- 106 dB Sensitivity
- Aluminum Heat sink
- Phenolic Diaphragm

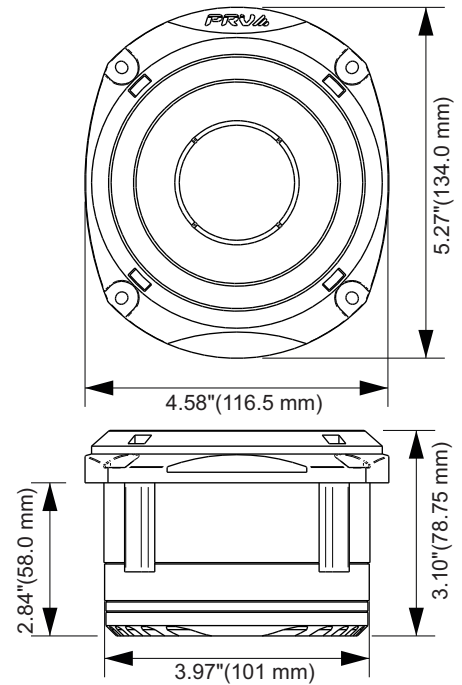

GENERAL SPECIFICATIONS

Nominal Impedance	8 Ohms
Rated Power Handling	100 Watts
Program Power	200 Watts
Sensitivity 2.83V at 1m*	106 dB
Recommended High Pass Crossover**	5000 Hz***
for Full Power Handling	*12 db/oct Crossover
Frequency Response at -10dB	4,000-20,000Hz
Voice Coil Diameter	1.83" (46.5 mm)
Voice Coil Wire	Copper
Voice Coil Former Material	Kapton®
Diaphragm Material	Phenolic
Flux Density	1.58 T
Magnet Material	Ferrite

EXTRA INFO

Overall depth	3.10" (78.75 mm)
Mounting Depth	2.84" (58.0 mm)
Overall Width	4.58" (116.5 mm)
Overall Height	5.27" (134.0 mm)
Cutout Diameter	4.41" (112.0 mm)
Net Weight	2.55 lbs (1.19 kg)
Shipping Weight	2.67 lbs (1.21 kg)
Carton Dimensions W x L x H	5.43" x 4.92" x 3.54" (138 x 125 x 90 mm)

Frequency Response Measured at 2.83v/1m

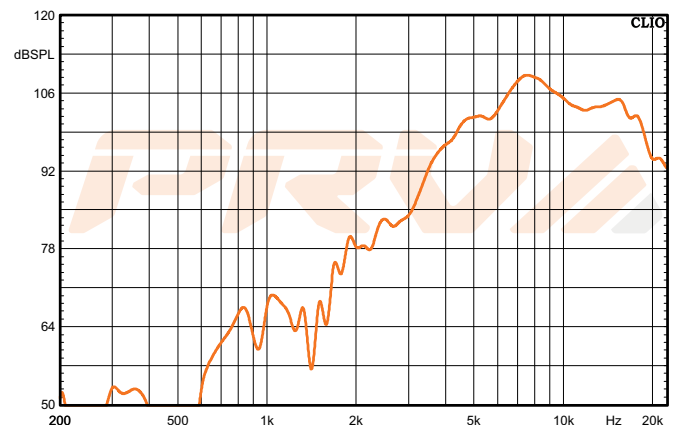

PRVA AUDIO USA (USA and Export) PRVA AUDIO BRAZIL (Brazilian Sales Only)
 FORT LAUDERDALE, FL SAO LEOPOLDO, RS
 support@prvaudio.com vendas@pvaudio.com.br
 www.prvaudio.com www.pvaudio.com.br