

6MB400

Professional Mid Bass Driver



KEY FEATURES

- 1.5" Voice coil
- 400 Watts continuous program power
- 94 dB Sensitivity
- 95 - 7,500 Hz



GENERAL SPECIFICATIONS

Nominal Diameter	6" (152 mm)
Nominal impedance	8 Ohm
Nominal Power Handling	200 Watts
Continuous Program Power (RMS)	400 Watts
Max Peak Power	800 Watts
Sensitivity 2.83V at 1m	94 dB
Recommended Hi Pass Crossover*	95 Hz*
<small>*For Full Power Handling</small>	<small>*12db Per Octave Crossover</small>
Frequency Response	95 - 7,500 Hz
Voice Coil Diameter	1.5" (38 mm)
Voice Coil Wire	CCAW
Voice Coil Winding Depth	12.0 mm
Former Material	Kapton
Magnetic Gap Depth	8.0 mm
Frame Material	Stamped Steel

THIELE-SMALL PARAMETERS

Equivalent Volume	Vas	5.69 l
Excursion (mathematical)***	Xmax	4.00 mm
Free Air Resonance	Fs	117.4 Hz
Mechanical Factor	Qms	8.97
Electrical Factor	Qes	0.64
Total Factor	Qts	0.60
Cone Area	Sd	147 cm ²
Mechanical Mass	Mms	9.80 g
Bl Factor	Bl	8.26 Tm
Dc Resistance	Re	6.1 Ohm
Inductance	Le	0.53 mH at 1 kHz
Mechanical Mass Without Air	Mmd	7.79 g
Mechanical Compliance	Cms	0.187 mm/N

EXTRA INFO

Overall Diameter	6.61" (168 mm)
Front Mount Baffle Cutout	5.63" (143 mm)
Mounting Depth	2.75" (70 mm)
Overall Depth	3.07" (78 mm)
Net Weight	4.80 Lbs (2.16 kg)
Shipping Weight	5.10 Lbs (2.32 kg)
Carton Dimensions W x L x H	7.09" x 7.09" x 3.35" (180 x 180 x 85 mm)

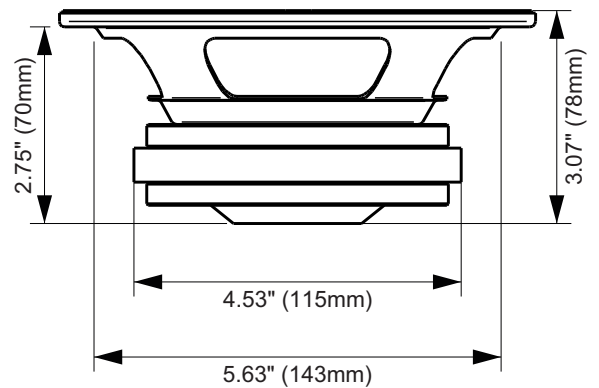
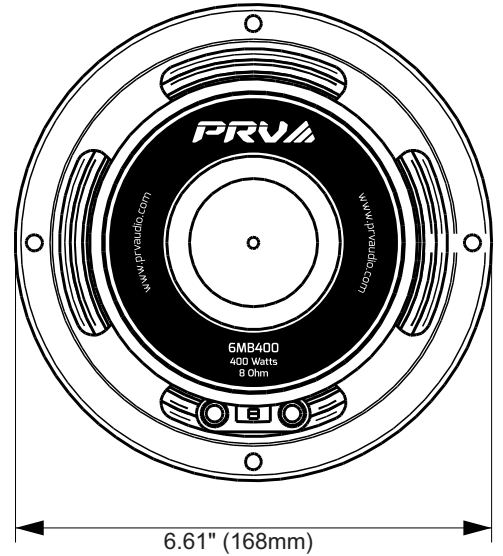

Impedance Curve - Free Air

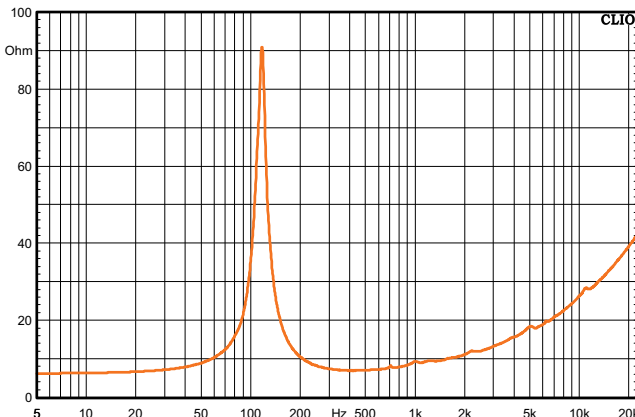

Frequency Response Measured at 2.83V/1m

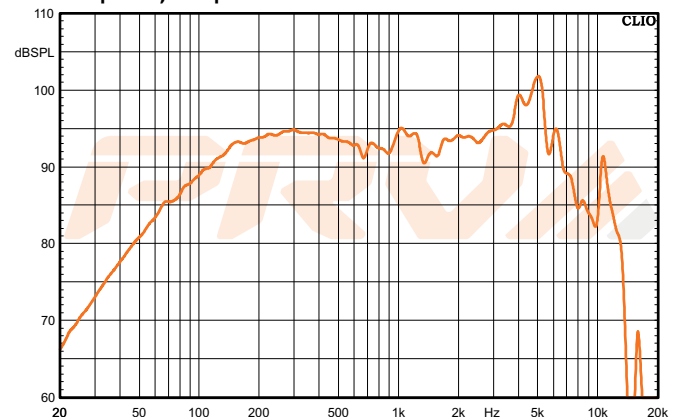

**Xmax=(Voice coil winding depth-Magnetic Gap depth)/2+ Magnetic Gap Depth/4
 *** T-S parameters measured after 2 hours at 1/2 Rated power, pink noise preconditioning test

PRVA AUDIO USA (USA and Export)
 POMPANO BEACH, FL
 support@prvaudio.com
 www.prvaudio.com