

# 21SW3000-NDY-4

Professional Low Frequency Driver



## KEY FEATURES

- Lightweight Neodymium Magnet assembly
- 1500 Watts continuous power handling
- 98 dB Sensitivity
- Reinforced Cone treated on both sides



## GENERAL SPECIFICATIONS

Nominal Diameter	21" (553 mm)
Nominal impedance	4 ohms
<b>Rated Power Handling</b>	<b>1500 Watts</b>
Program Power	3000 Watts
<b>Sensitivity 2.00V at 1m</b>	<b>98 dB</b>
Recommended Hi Pass Crossover*	45 Hz*
<small>*For Full Power Handling</small>	<small>*12db Per Octave Crossover</small>
<b>Frequency Response at -10dB</b>	<b>35 - 1,800 Hz</b>
Voice Coil Diameter	4.5" (115 mm)
Voice Coil Wire	Copper
Voice Coil Winding Depth	34.0 mm
Former Material	Glass Fiber
Magnetic Gap Depth	15.0 mm
Frame Material	Die cast aluminum

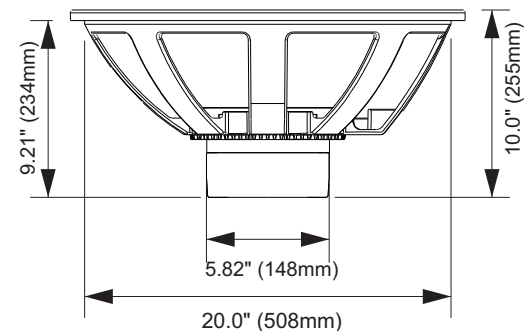
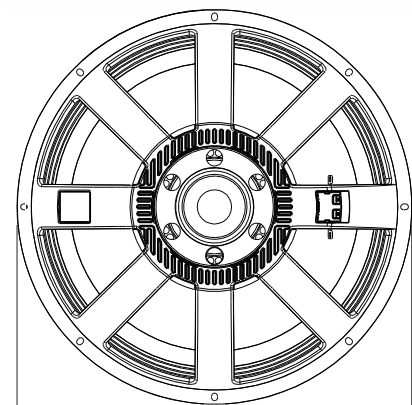

## THIELE-SMALL PARAMETERS

Equivalent Volume	Vas	337.3 l
Excursion (mathematical)***	Xmax	13.25 mm
Free Air Resonance	Fs	31.4 Hz
Mechanical Factor	Qms	11.9
Electrical Factor	Qes	0.35
Total Factor	Qts	0.34
Cone Area	Sd	1924 cm <sup>2</sup>
Mechanical Mass	Mms	392 g
Bl Factor	BL	26.65 Tm
Dc Resistance	Re	3.2 Ohms
Inductance	Le	1.45 mH at 1 kHz
Mechanical Mass Without Air	Mmd	345.2 g
Mechanical Compliance	Cms	0.065 mm/N

## EXTRA INFO

Overall Diameter	21.53" (547 mm)
Front Mount Baffle Cutout	20.0" (508 mm)
Mounting Depth	9.21" (234 mm)
Overall Depth	10.0" (255 mm)
Net Weight	24.0 Lbs (10.9 kg)
Shipping Weight	28.6 Lbs (13.0 kg)
Carton Dimensions W x L x H	23.2" x 22.4" x 10.8" (590 x 570 x 275mm)

Frequency Response Measured at 2.00V/1m

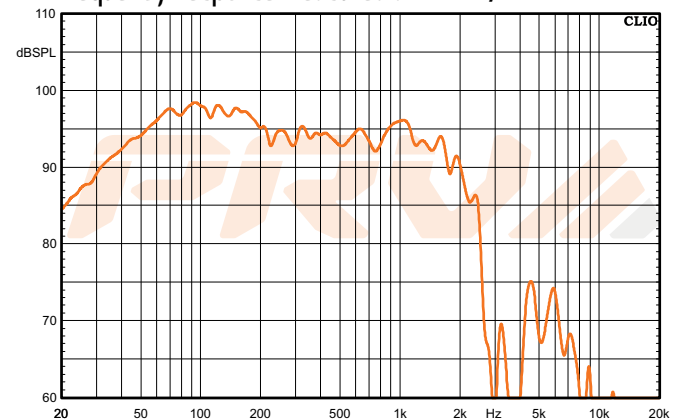

PRV AUDIO USA (USA and Export) PRV AUDIO BRAZIL (Brazilian Sales Only)  
 FORT LAUDERDALE, FL SAO LEOPOLDO, RS  
 support@prvaudio.com vendas@pvaudio.com.br  
 www.prvaudio.com www.pvaudio.com.br

\*\*\*Xmax=(Voice coil winding depth-Magnetic Gap depth)/2+ Mgnetic Gap Depth/4